

Users Guide

Serial LCD+ Ver. 1.4

The Serial LCD+ is a 4x20 LCD display with a built-in bi-directional serial interface. Unlike older style LCD displays the Serial LCD+ is controlled using standard RS-232 serial signals from a host computer or microcontroller. The LCD+ supports the following serial data rates 2400, 4800, 9600, 19,200, 38,400 and 57,600 baud.

Table of Contents

LCD+ Pin definitions	2
Interfacing the LCD+	3
Initial power-up test	4
Keypad Interface	4 - 5
ADC Interface	5 - 6
Defining custom characters	6
Relay Interface	6
LCD+ Control Codes	7
Retrieving LCD+ settings	7
LCD+ Demo Software	7
Example Code	8 - 10
Specifications and Dimensions	11

Important Warranty Information

NetMedia, Inc. warrants this product against defects in materials and manufacturing workmanship for a period of 90 days. Warranted returns will be repaired or replaced at the option of NetMedia, Inc. Products showing signs of alterations or mechanical damage are not eligible for warranty replacement. To return a product for warranty consideration, send the product with a copy of the original invoice and a brief description of the problem to:

NetMedia, Inc. Attn: Warranty Repair
10940 N. Stallard Place
Tucson, AZ 85737.

The warranted item or its replacement will be returned via standard shipping. For expedited or foreign shipping please include your credit card number with your return shipping instructions.

LCD+ Pin Definitions

Figure 1 shows a top down view (Not the backside view!) of the LCD+. The LCD display module has been removed to make the connections more visible. *Note: The empty 8-pin socket is for future use and not used.*

Figure 1

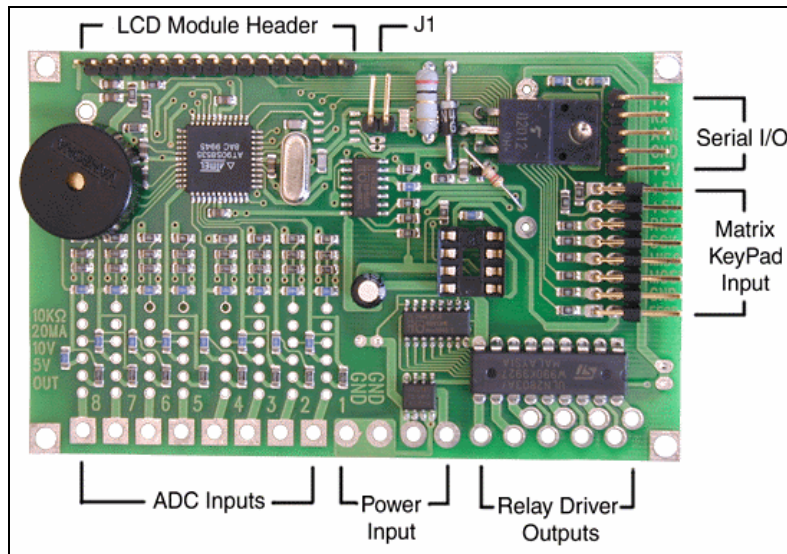

Serial I/O

The Serial I/O header is made up of 5 connections. The first connection marked **TX** is the LCD+ serial output. **TX** connects to the host computers/microcontrollers serial input. The Next connection marked **RX** is the LCD+ serial Input. **RX** connects to the host computers/microcontrollers serial output. The middle connection marked **ATN** is not currently implemented and should be left unconnected. The connection marked **GND** is the serial I/O ground connection and connects to the host computers/microcontrollers serial ground connection. The connection marked **+5v** is a courtesy +5volt 20mA voltage source provided by the LCD+ voltage regulator. Note all four of the LCD+ **+5v** courtesy connections are tied to the same voltage regulator, the combined load for all of these connections must not exceed 20mA.

Power Input

The Power input section consists of four through holes (Solder Pads). The two holes marked **GND** are grounds. The hole marked **+5.5 to +15V** is tied to the LCD+ modules onboard regulator. The hole marked **+5v** ties to the +5v buss and is used to bypass the LCD+ onboard regulator when a regulated 5volt source is supplied. *Note: To insure proper backlight function when running the LCD+ from a regulated 5volt source, you must connect both the regulator input (hole marked **+5.5 to +15V**) and the 5volt input (hole marked **+5**) connections together.*

To power up the LCD+ connect your 5 - 15volt dc supply's positive lead to the hole marked +5 to +15V, then connect your supply's ground or negative lead to either of the two ground (GND) holes. The hole marked **+5v** is a courtesy +5volt 20mA voltage source provided by the LCD+ voltage regulator.

Important Note: Reversing the positive and negative power connections will cause immediate damage to the LCD+ and void your warranty!

J1

The **J1** jumper connection sets the LCD+ to its inverted serial receive mode. If a jumper is installed across J1 the LCD+ will read logically inverted serial inputs. J1 factory default setting = no jumper installed.

ADC Inputs

The eight ADC inputs are labeled **1 – 8**. By default all ADC input are set to read voltage in the 0 to 5volt range. *Note exceeding this range may damage the ADC inputs.*

Above each of the ADC inputs there are provisions for input voltage range jumpers, the use of these optional jumpers will be explained later in this text.

Relay Driver Outputs

There are nine Relay Driver connections (Labeled on the underside of the board as R1-8 and RLY+VDC). The connections labeled **R1 – 8** are the relay driver chip outputs, the **RLY+VDC** connection provides access to the ULN2803A relay driver chip's internal back EMF protection diodes.

Matrix KeyPad Input

The KeyPad input connections (Visible in figure 1) are the upper most eight of the 8x2 header connection. The lower most eight of the 8x2 header connection (Not visible in figure 1) are used by the factory for programming and should be left unconnected.

Interfacing the LCD+

The LCD+ can be controlled using any computer or microprocessor supporting 1200 - 57,600K data rates with a 8,N,1 data format (**8** data bits, **No** parity, **1** stop bit). Figure 2 shows the connections required to interface the LCD+ to a standard PC serial port. The lighter colored inter-pin connections are used to bypass software flow control and may be required for

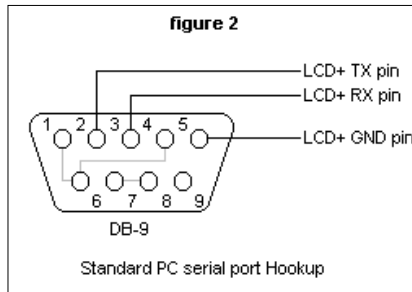

older computers running DOS based serial communication programs or if you use a serial communication program that requires hardware handshaking/ Flow control.

Initial power-up test

Before connecting the LCD+ to your PC or microcontroller you should do a power-on check, this insures your power connections are correct and prevents you from damaging your PC should there be a problem.

Before connecting your 5.5 – 15volt dc power supply to the LCD+, you should check and recheck your power connections. Confirm that your power supply's (+) or positive lead is connected to the connection labeled +5 to +15V and your power supply's (– negative) or ground lead is connected to the connection marked GND.

On initial power up the LCD+ should display “9600 BAUD”. If after connecting power to the LCD+ you do not see the power-up message check your power connections, your power supply may not be providing enough output current.

Once you have seen the power-up message you are ready to connect the LCD+ to your computer. With your computers power off, follow the hookup diagram in figure 2 and connect the LCD+ to your computer's serial port. Once you have the LCD+ connected, turn on your computer and run a serial terminal program such as the LCD+ demo program or HyperTerminal.

If everything is connected and configured properly, all keystrokes sent through the program's text window will appear on the LCD+ display.

Keypad Interface

The keypad interface supports matrix keypads up to 4x4 in size (16 keys). Instead of predefining the keypad keys serial data format as 0 though 15, each key of the keypad's keys is serially represented by a user definable byte value. This user definable value or “Tag” is stored within the LCD+ EEPROM as a 0 - 15byte array. Each byte of the array corresponds to a key on the keypad (i.e. key 0 corresponds to byte0 of the array). Whenever a key is pressed, the stored byte representation for that key number is serially sent. *Note: The keypad is not a polled feature. Key press events are immediately sent out the serial TX pin.*

Figure 3 shows how to interface a common 4x4 matrix keypad. Pin1 of the LCD+ matrix keypad header is located on the top row closest to the serial header. When using a smaller keypad size the connection/connections for the unused row and or column is simply left disconnected. For example if the keypad in **figure 3** had four rows but only three columns the connection to Pin8 (from the now missing column) would be left disconnected.

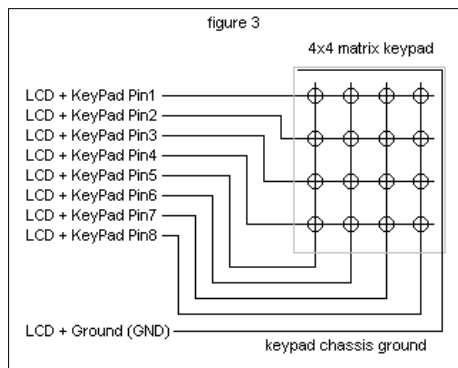

Keypad Options

The keypad feature is supported by five user definable options or “modes”. Setting these modes is done by sending a CTRL-X followed by your command byte containing the desired “modes”. Only the lower 5 bits of the mode command byte are used. As shown is Table 1, placing a 1 in any of these lower 5 bits turns its corresponding option on, and a 0 turns it off

Table 1

Mode Byte	Name	Description
B0	1 = “Key Beeps”	Beep buzzer during each key press
B1	1 = “Key Press format”	Send 1 byte for key down and 1 for key up
B2	1 = “LCD Echo”	Echo key press data ASCII representation to LCD display
B3	1 = “Mask Key Presses”	Display all key presses as asterisks on LCD
B4	1 = “Auto Backlight”	Turns on backlight with any key press and off 4 seconds after last key press

Changing the Keypad's key “Tags”

The LCD+ keypad Tags may be serially changed by sending a CTRL-T (20 Decimal) followed by 16 bytes containing the new keypad values.

Using the Keypad interface for input

If a CTRL-Y is sent to the LCD+, the keypad input pins are read as a port. And the logical state of the eight keypad input pins is then returned in a byte format.

ADC Interface

The LCD+ is equipped with eight 10Bit Analog to digital converters (ADCs). Labeled 1 – 8 on the LCD+ board, the ADCs are serially requested as 1 – 8. An ADC reading request is initiated by sending the ADC function byte (Ctrl-V or 22 Decimal) immediately followed by a byte containing the requested ADC channel number (0-7 Decimal).

After taking the ADC measurement, the LCD+ sends a 10bit result out the TX pin in two bytes (seen in figure 4). The first byte contains the lower eight bits of the 10Bit result while the second byte contains the remaining 2 bits in the 0 and 1 position. After reception, the host computer or microcontroller can shift these two bytes into a 10bit result.

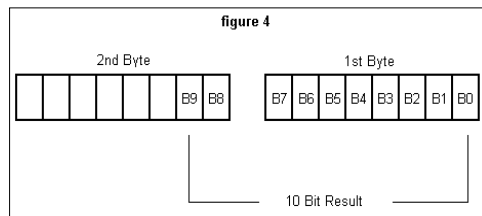

Each ADC channel has four jumper selectable input ranges. By default (with no Jumper installed) this range is 0-5v. The additional ranges shown in Figure 4.1 are set using jumper wire or installing a header-pin strip and using conventional 100mil jumpers. Only the top four holes are used, the bottom most two should be left unconnected.

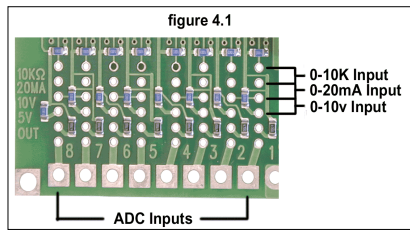

Note: Never install more than one jumper per row.

Defining custom characters

The standard LCD+ character also contains eight user definable characters. Each of these eight characters (CTRL 0 – 7) is 5 pixels wide and 8 pixels tall and can be used for making things like arrows, custom symbols or any other non-standard character. Writing a new custom character to EEPROM is accomplished by sending the custom character write command byte (CTRL-S or Decimal 19), the characters number (0-7 Decimal) followed by the eight bytes that makeup the new character. **Figure 5** shows how each of those eight bytes correspond to a character.

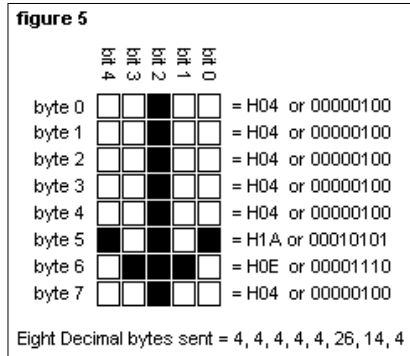

Figure 5 shows how each of those eight bytes correspond to a character.

Relay Interface

The ULN2803A relay driver chip used in the LCD+ consists of eight open collector Darlington transistors (NPN Type).

Figure 6 shows the proper method of connecting relays to the LCD+.

A set relay command is initiated by sending the relay function byte (CTRL-R or 18 Decimal) followed by a relay set byte. Each relay's state is represented by its own Bit in the relay set byte (R1 = B0 etc).

For example, if you wanted to turn both relay 1 and 8 on and 2-7 off, the relay set byte would be 01111110 or 126 Decimal.

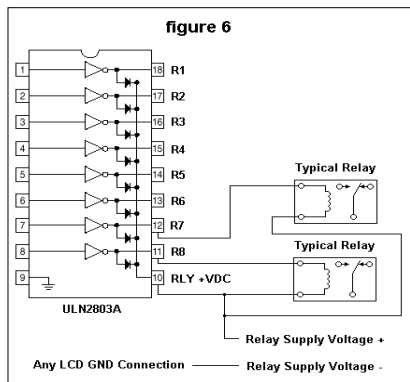

LCD+ Control Codes

Control Code	Function	Total bytes needed + Command +Data	Return Data
Ctrl-A	Cursor Home	1Byte(01Hex or 1Dec.)	None
Ctrl-B	Set/Adjust Backlight Brightness	2Bytes(02Hex or 2Dec.) + 0-255	None
Ctrl-C	Set/Adjust Contrast	2Bytes(03Hex or 3Dec.) + 0-255	None
Ctrl-D	Hide Cursor	1Byte(04Hex or 4Dec.)	None
Ctrl-E	Underline Cursor	1Byte(05Hex or 5Dec.)	None
Ctrl-F	Block Cursor	1Byte(06Hex or 6Dec.)	None
Ctrl-G	Sound Bell/Buzzer	1Byte(07Hex or 7Dec.)	None
Ctrl-H	Backspace	1Byte(08Hex or 8Dec.)	None
Ctrl-I	Horizontal tab	1Byte(09Hex or 9Dec.)	None
Ctrl-J	Line feed	1Byte(0Ahex or 10Dec.)	None
Ctrl-K	Reverse line feed	1Byte(0Bhex or 11Dec.)	None
Ctrl-L	Form feed/Clear screen	1Byte(0Chex or 12Dec.)	None
Ctrl-M	Carriage return	1Byte(0Dhex or 13Dec.)	None
Ctrl-N	Backlight on	1Byte(0Ehex or 14Dec.)	None
Ctrl-O	Backlight off	1Byte(0Fhex or 15Dec.)	None
Ctrl-P	Set cursor position	2Bytes(10Hex or 16Dec.) + 1-80	None
Ctrl-Q	Clear column	1Byte(11Hex or 17Dec.)	None
Ctrl-R	Set Relays	2Bytes(12Hex or 18Dec.) + 0-255	None
Ctrl-S	Define custom character	3Bytes(13Hex or 19Dec.) + 0-7 + 1Bytes	None
Ctrl-T	Download Keypad Tags	17Bytes(14Hex or 20Dec.) + 16 New keys	None
Ctrl-U	Set Baud rate	2Bytes(15Hex or 21Dec.) + Dec191=2400, Dec95=4800, Dec47 = 9600, Dec31=14,400, Dec23=19,200, Dec15= 28,800, Dec11= 38,400, Dec7=57,600	None
Ctrl-V	Read ADC inputs	2Bytes(16Hex or 22Dec.) + 1-8	2 Bytes
Ctrl-W	Change Bell/Buzzer Frequency	2Bytes(17Hex or 23Dec.) + 0-255	None
Ctrl-X	Set Keypad modes	2Bytes(18Hex or 24Dec.) + 0-255	None
Ctrl-Y	Read Keypad input as port	1Byte(19Hex or 25Dec.)	1 Byte
Ctrl-Z	Get LCD+ EEPROM settings	1Byte(1Ahex or 26Dec.)	20 Bytes
None	Display custom character 0	1Byte(80Hex or 128Dec.)	None
None	Display custom character 1	1Byte(81Hex or 129Dec.)	None
None	Display custom character 2	1Byte(82Hex or 130Dec.)	None
None	Display custom character 3	1Byte(83Hex or 131Dec.)	None
None	Display custom character 4	1Byte(84Hex or 132Dec.)	None
None	Display custom character 5	1Byte(85Hex or 133Dec.)	None
None	Display custom character 6	1Byte(86Hex or 134Dec.)	None
None	Display custom character 7	1Byte(87Hex or 135Dec.)	None

Retrieving the LCD+ EEPROM settings

The LCD+ settings and configuration data is stored within an on-board EEPROM. Access to this data is provided through the CTRL-Z command . Whenever a CTRL-Z is sent, the LCD+ responds by sending a 20byte packet of data containing the current EEPROM settings. The table below shows the order and type of data returned.

Byte order	Data
1	Bell/Buzzer Current Frequency value (0-255)
2	Current LCD Backlight value (0-255)
3	Current LCD contrast value (0-255)
4	Current Keypad "mode" settings (000XXXX) as Byte
5-20	Current Keypad "Tags" (0-255) x 16

LCD+ Demo Software

The LCD+ demo program is provided to help first time users test and become acquainted with the LCD+'s many features. This demo program was designed to run on computers running Microsoft Windows 95/98.

Once you have installed the demo program you will need to set your computer's comport before use. On the demo programs first screen, click the button labeled "Select/Configure Comport". In the new box marked "Comport properties", select the comport number that corresponds to the one your LCD+ is or will be connected to. Then make sure 9600 baud is selected (all LCD+ modules are shipped in 9600 baud mode). Before clicking the OK button, note the setting of the "Local Echo" option box, this option should be set to on.

With your LCD+ module connected and powered up, click on the button marked open port. If your LCD+ is properly attached/configured, the LCD+ demo program will download the LCD+ module's current EEPROM settings and display them under both the "KeyPad" and "LCD settings" tabs.

If you are unsure of what a particular control item does, hold your mouse cursor over it and a "tool tip" should pop up and explain it.

Example Code

BX-24 Example

Required Connections:

LCD+ TX to BX-24 Pin12
LCD+ RX to BX-24 Pin11
LCD+ GND to BX-24 Pin23
LCD+ 5.5-15volt input connected to appropriate power source.

```
Dim Com3_Out(1 To 40) As Byte 'Com3 Out Buffer
Dim Com3_In(1 To 30) As Byte 'Com3 In Buffer
Dim I As Byte
Const Clear_Screen As Byte = 12
Const Postion_Cursor As Byte = 16
Const Brightness As Byte = 2
Const Sound_Bell As Byte = 7
Const Bell_Freq As Byte = 23
```

```
'-----
Sub Main()
```

```
    'Open Com3 serial port queues
    Call OpenQueue(Com3_Out, 40)
    Call OpenQueue(Com3_In, 30)
```

```

'Define pins for Com3 (RX = pin12, TX= pin11)
Call DefineCom3(12, 11, bx1000_1000)
'Open Com3 at 9600,N,8,1
Call OpenCom(3,9600, Com3_In, Com3_Out)
'Wait for a bit
Call Delay(0.5)

'Clear LCDs screen
Call PutQueueStr(Com3_Out,Chr(Clear_Screen))

'Put cursor at position 27 and print "READY?"
Call PutQueueStr(Com3_Out,Chr(Postion_Cursor) & Chr(27))
Call PutQueueStr(Com3_Out, "READY?")
Call Sleep(1.0)

'Clear LCD screen
Call PutQueueStr(Com3_Out,Chr(Clear_Screen))

Call PutQueueStr(Com3_Out,Chr(Postion_Cursor) & Chr(28))
Call PutQueueStr(Com3_Out, "AIM")
Call Sleep(1.0)

'Clear LCD screen
Call PutQueueStr(Com3_Out,Chr(Clear_Screen))

Call PutQueueStr(Com3_Out,Chr(Postion_Cursor) & Chr(28))
Call PutQueueStr(Com3_Out, "FIRE!")
Call Sleep(0.5)

'Increment the bell frequency from 1 to 230 and sound bell
'on each freq.
For I = 1 to 230
    Call PutQueueStr(Com3_Out,Chr(Bell_Freq) & Chr(I))
    Call Sleep(15)
    Call PutQueueStr(Com3_Out,Chr(Sound_Bell))
Next

'Clear LCD screen
Call PutQueueStr(Com3_Out,Chr(Clear_Screen))

Call PutQueueStr(Com3_Out,Chr(Postion_Cursor) & Chr(27))
Call PutQueueStr(Com3_Out, "BOOM!!!")

'Increment the Backlight level from 1 to 220
For I = 1 to 220
    Call PutQueueStr(Com3_Out,Chr(Brightness) & Chr(I))
    Call Sleep(5)
Next

Call Sleep(1.0)

Call PutQueueStr(Com3_Out,Chr(Postion_Cursor) & Chr(25))
Call PutQueueStr(Com3_Out, "You sunk my")
Call PutQueueStr(Com3_Out,Chr(Postion_Cursor) & Chr(65))
Call PutQueueStr(Com3_Out, "BATTLESHIP!")

```

```
Call Sleep(3.0)

Call PutQueueStr(Com3_Out,Chr(Postion_Cursor) & Chr(4))
Call PutQueueStr(Com3_Out, "The New LCD+")
Call PutQueueStr(Com3_Out,Chr(Postion_Cursor) & Chr(23))
Call PutQueueStr(Com3_Out, "CAN DO IT ALL!")
Call PutQueueStr(Com3_Out,Chr(Postion_Cursor) & Chr(40))
Call PutQueueStr(Com3_Out, "ADCs, Relays, Keypad")
Call PutQueueStr(Com3_Out,Chr(Postion_Cursor) & Chr(61))
Call PutQueueStr(Com3_Out, "Sound & I/O Input")

Do

Loop

End Sub
```

Specifications

Power Requirements	5.5 to 15V dc @ 9mA (200mA max backlight on)
Serial I/O	RS232 or Inverted TTL (2400 to 57,600 8,N,1)
ADC input Leakage	50nA Typical
Relay Driver Outputs	500mA max per output
Keypad Input	4x4 Matrix type
LCD type	4 x 20 Supertwist
Temperature limits	0° to 50° C Operating and -10° to 60° storage

Dimensions

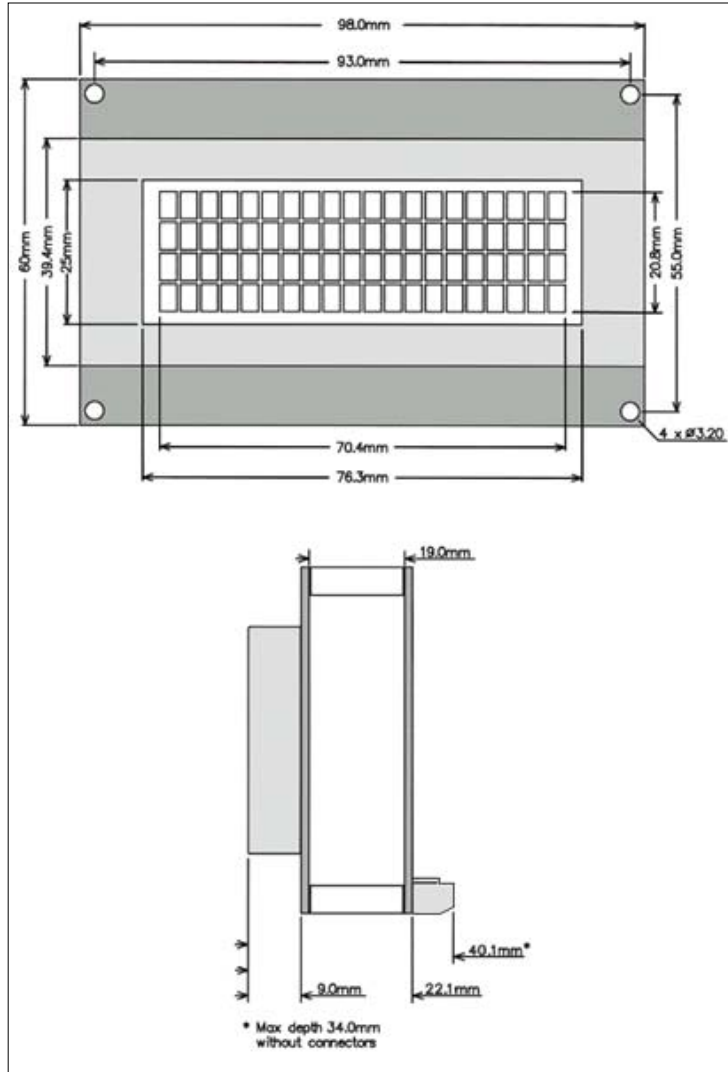



Copyright © 1999 - 2000 NetMedia Inc. All rights reserved
Basic Express, BasicX, BX-01 and BX-24 are trademarks of NetMedia, Inc.