

# LCDX Hardware Guide

Ver 1.6



## Table of Contents:

Overview.....	2
LCDX Function Library (Supplied on CD, see software guide for usage) .....	2
LCD Interface .....	2
Connectors .....	2
LCD+ Pin Definitions .....	3
Power Inputs .....	3
Initial power-up test .....	3
Com1 Download Port and Com1 Aux .....	4
Keypad Interface.....	4
J1.....	5
ADC Inputs .....	5
Relay Driver Outputs .....	5
Additional I/O .....	6
Pin Assignments .....	6
Misc. Specifications.....	6
Dimensions .....	7
Warranty Information .....	7

## Overview

LCDX is a BasicX Microcontroller with a built-in 4x20 LCD display. The All-In-One design saves both space and time by allowing you to build powerful display and user input orientated devices with one easy to integrate module. The LCDX features are controlled using the “LCDX Function Library” or by user modified/supplied code.

## LCDX Function Library (Supplied on CD, see software guide for usage)

The LCDX Function Library is a Basic file containing Subroutines and Functions for controlling the various LCDX features. Including this file into your BasicX project makes the LCDX features appear as standard built-in BasicX language commands (example: Beep, PutRelay, LCDScrollUp).

## LCD Interface

LCDX consists of a BasicX-24 processor connected to a 4x20 LCD display. The on-board BasicX microcontroller communicates with the LCD using a 4 Bit parallel interface. A total of 7 BasicX I/O lines are used to communicate with the LCD, three are dedicated to the LCD. The remaining four I/O lines function as both LCD data lines and inputs for the keypad interface. Two additional I/O lines are dedicated to the LCDs contrast and Backlight controls.

## Connectors

The ADC and relay connections are designed for use with screw type or plugable type “Euro” connectors. Screw type connectors are only provided with the LCDX development kit and are not currently available separately from NetMedia, Inc. Connectors can also be purchased from Jameco.com as PN 99397 & 99426. You will need to order 5 99397 3-pin connectors and 1 99426 2-pin connector for each LCDX.

## LCD+ Pin Definitions

Figure 1 shows a top down view (Not the backside view!) of the LCDX. The LCD display module has been removed to make the connections more visible.

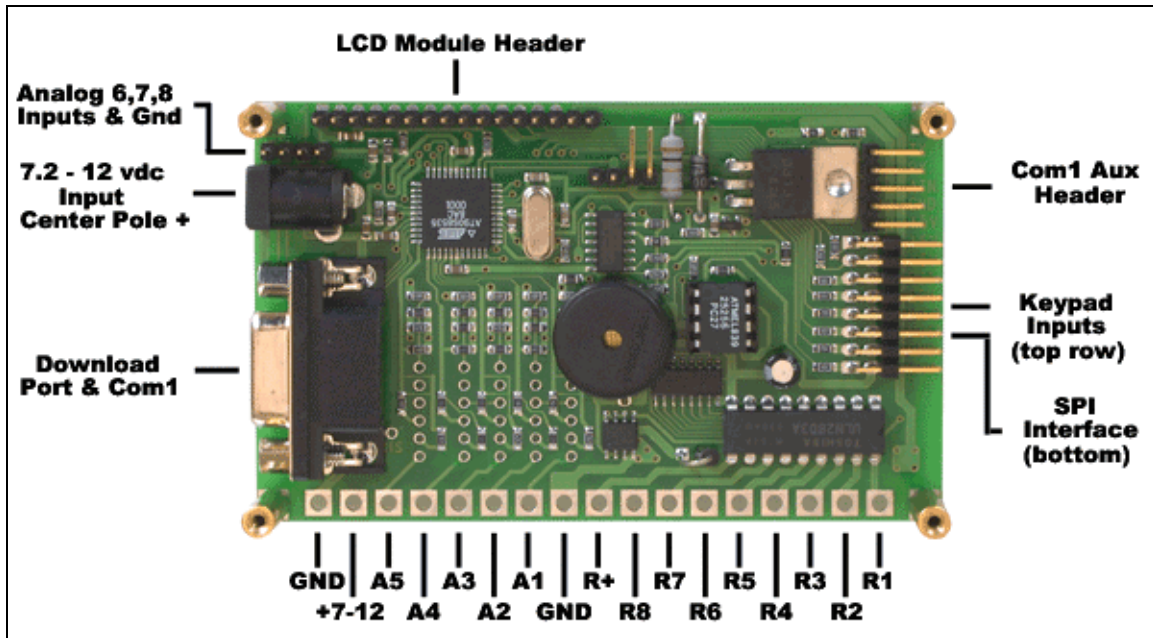

Figure 1

## Power Inputs

The LCDX requires a 7.2 – 12Vdc 200mA supply. Power can be connected to either the barrel connector (Center pole positive) or the V+ & GND pads on the 17 pin solder strip connector as seen in figure 1 (V+ is marked “+7-12 in figure 1).

***Important Note: Reversing the positive and negative power connections will cause immediate damage to the LCDX and void your warranty!***

## Initial power-up test

Before connecting the LCDX to your PC or microcontroller you should do a power-on check, this insures your power connections are correct and prevents you from damaging your PC should there be a problem. On initial power up the LCDX should start its factory loaded demo program. If after connecting power to the LCDX you do not see demo program start to run check your power connections, and you power supply.

## Com1 Download Port and Com1 Aux

There are two connections for Com1 on the LCDX board. The first is the DB-9 connector, it's most commonly used for downloading user programs from the PC to the LCDX. The second Com1 connector is a 5-pin right angle header found on the other side of the board. The 5-pin headers first connection marked **TX** is Com1's serial output. **TX** connects to the host computers/microcontrollers serial input. The Next connection marked **RX** is the LCDX serial Input. **RX** connects to the host computers/microcontrollers serial output. The middle connection marked **ATN** is the attention line used by the LCDX during downloads. The **ATN** connects to the PC serial ports Pin4 if used for downloading, otherwise should be left disconnected. The connection marked **GND** is the serial I/O ground connection and connects to the host computers/microcontrollers serial ground connection. The connection marked **+5v** is a courtesy +5volt 40mA voltage source provided by the LCDX voltage regulator.

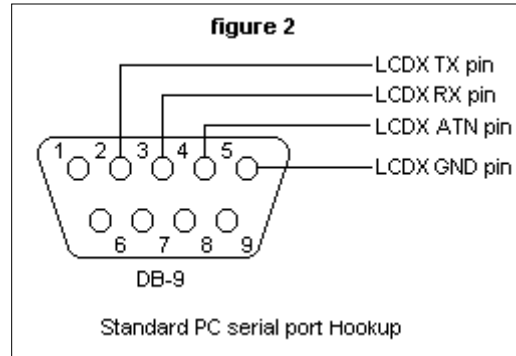

**Note1** Both Com1 connections are true serial level tolerant and may be connected directly to any standard serial port. **IMPORTANT!** Both Com1 connectors are physically tied together. This means if one connector is tied to a serial level device the other connector will have the same serial level voltages present and cannot be used for TTL level devices without protection.

**Note2** all of the LCDX **+5v** courtesy connections are tied to the same voltage regulator, the combined load for all of these connections must not exceed 40mA.

## Keypad Interface

The keypad interface supports matrix keypads up to 4x4 in size (16 keys). The Keypad input connections (Visible in figure 1) are the upper most eight of the 8x2 header connection. The lower most eight of the 8x2 header connection contain the SPI pins and power connection.

**Figure 3** shows how to interface a common 4x4 matrix keypad. Pin1 of the LCDX matrix keypad header is located on the top row closest to the serial header. When using a smaller keypad size the connection/connections for the unused row and or column is simply left disconnected. For example if the keypad in **figure 3** had four rows but only three columns the connection to Pin8 (from the now missing column) would be left disconnected.

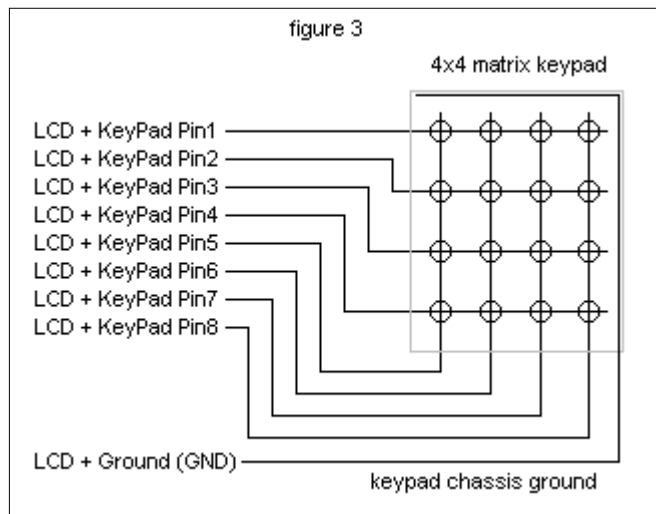

## J1

The **J1** jumper connection sets the LCD+ to its inverted serial receive mode. J1 factory default setting = no jumper installed. If a jumper is installed across J1 the LCDX will read logically inverted serial inputs. The J1 connector is the only 2-pin right angle connector on the LCDX board and is located by the LCD header.

## ADC Inputs

The 5 ADC inputs are labeled **A1 –A5**. Each ADC channel has four jumper selectable input ranges. By default (with no Jumper installed) this range is 0-5v. The additional ranges shown in Figure 4.1 are set using jumper wire or installing a header-pin strip and using conventional 100mil jumpers. Only the top four holes are used, the bottom most two should be left unconnected.

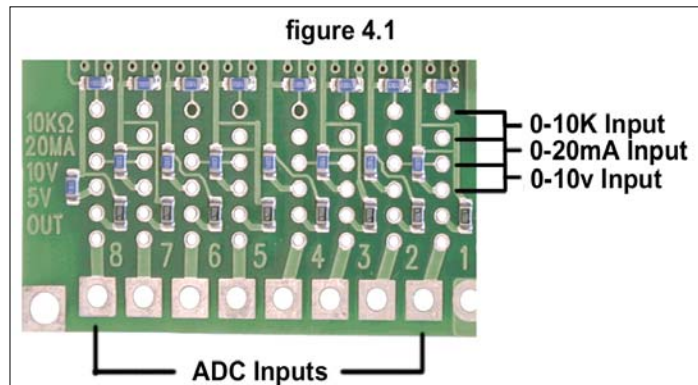

**Note1:** Never install more than one jumper per row.

**Note2:** Exceeding the input will damage the ADC inputs and void your warranty.

## Relay Driver Outputs

There are nine Relay Driver connections (Labeled on the underside of the board as R1-R8 and RV). Connections **R1 –R8** are the relay driver chip outputs, the **RV** connection provides access to the ULN2803A relay driver chip's internal back EMF protection diodes (Connection RV shown as RLY+VDC in the schematic below).

The ULN2803A relay driver chip used in the LCDX consists of eight open collector Darlington transistors (NPN Type). Figure 6 shows the proper method of connecting relays to the LCD+.

A set relay command is initiated by sending the relay function byte (CTRL-R or 18 Decimal) followed by a relay set byte. Each relay's state is represented by its own Bit in the relay set byte (R1 = B0 etc). For example, if you wanted to turn both relay 1 and 8 on and 2-7 off, the relay set byte would be 10000001 or 129 Decimal.

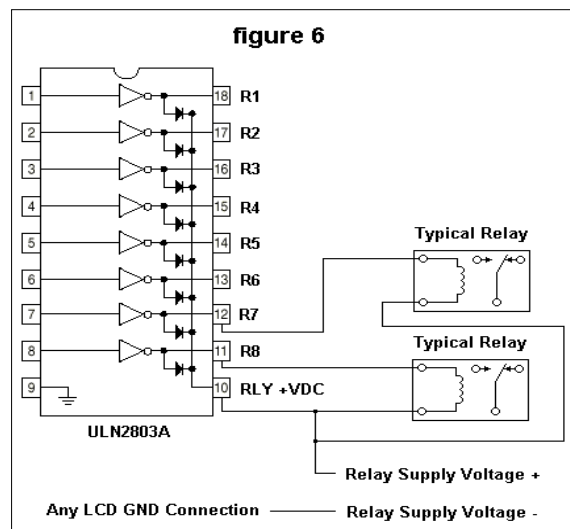

### Additional I/O

Five additional I/O pins are available on the LCDX. The 2 Pin EE header (Marked EE on the bottom side of the board) contains 2 standard I/O pins (see below for more details) and the 4-pin header beside the DB-9 connector contains the remaining 3 Analog inputs (Channels 6-9) and ground.

### Optional Mounting Bezel

The self-adhesive mounting bezel provides a “Finished” look when mounting the LCDX in a panel. The LCDX bezel is included with the LCDX development kit and can also be purchased separately.

### Pin Assignments

<b>Software to Hardware Pin Map</b>			
<b>Device</b>	<b>Function</b>	<b>Software Pin Name</b>	<b>Comments</b>
LCD Data Line	LCD Data/Command Input	40	
LCD Read Line	LCD Read/Write Input	42	
LCD Enable	LCD Enable Input	43	
LCD Bus	LCD Data Buss	19-22	Shared With KeyPad Input
Relay Output	Relay Output Driver Chip	15	Uses SPI Buss 15 is Chip Enable
ADC Inputs 1-8	Analog Inputs	30-37	Reversed order. ie ADC1=Pin37
EE1	Aux I/O pin	16	Also Int1
EE2	Aux I/O pin	17	Also Int0
Keypad	KeyPad Interface	23-26	LCD Bus used as other 4 inputs

### Misc. Specifications

Power Requirements	7.2 to 12V dc @ 34mA (200mA max backlight on)
Serial I/O	RS232 or Inverted TTL (1200 to 115,200 8,N,1)
ADC input Leakage	50nA Typical
Relay Driver Outputs	500mA max per output
Keypad Input	4x4 Matrix type
LCD type	4 x 20 Supertwist
Temperature limits	0° to 50° C Operating and -10° to 60° storage

## Dimensions

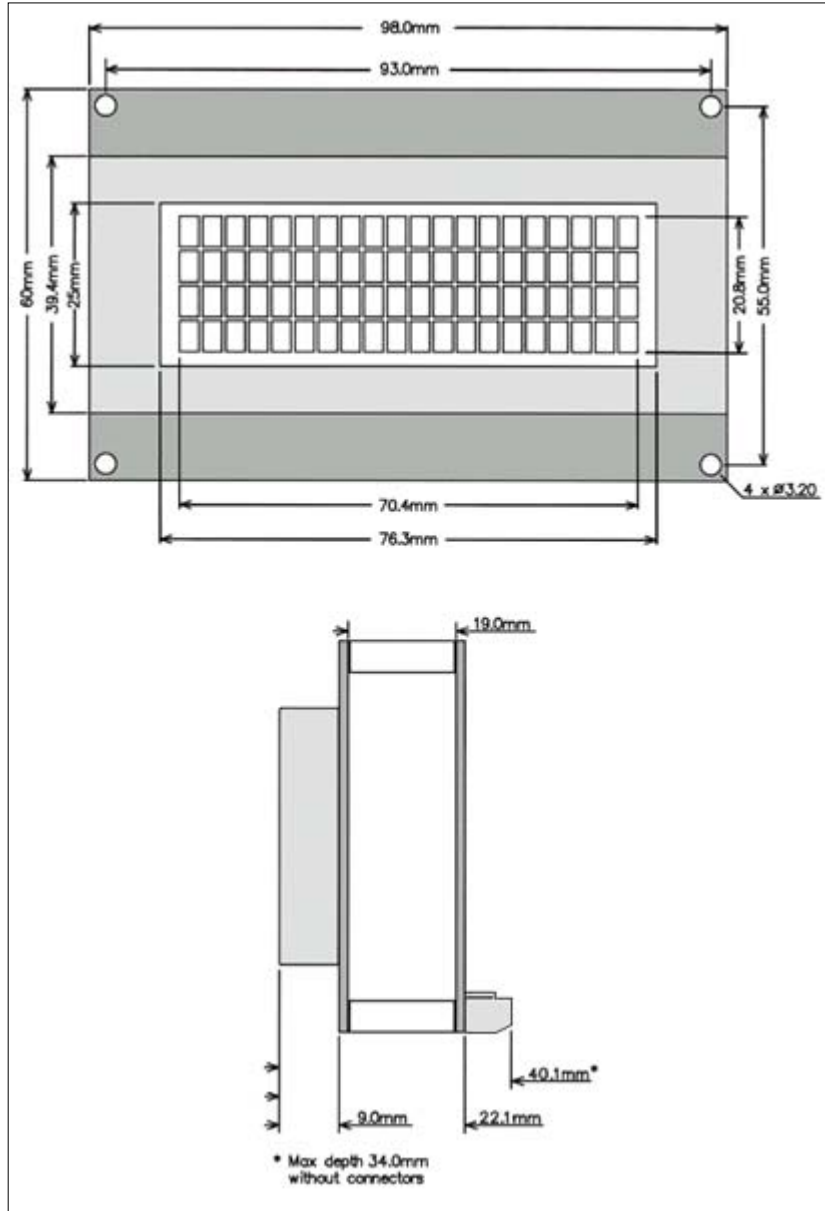

## **Warranty Information**

NetMedia warrants this product against defects in materials and manufacturing defects for a period of 90 days from date of original purchase. Warranted returns will be repaired or replaced at the option of NetMedia, Inc. Products showing signs of alterations or mechanical damage are not eligible for warranty replacement. To return a product for warranty consideration, send the product with a copy of the original invoice, your contact information including phone number and a brief description of the problem to:

NetMedia, Inc. Attn: Warranty Repair  
10940 N. Stallard Place  
Tucson, AZ 85737.

The warranted item or its replacement will be returned via standard shipping. For expedited or foreign shipping please include your credit card number with your return shipping instructions.